



HINO
driven to perfection

Australia

BULLBAR FITTING INSTRUCTIONS

TO SUIT: HINO 500 SERIES EURO 5 2017+

PART NUMBERS: **P2CFHN6510SYF**

REV: A: 07.02.23

Step1.

Park the vehicle on level ground and apply the park brake.
Check installation hardware and read fitting instructions before commencing.

Note: The vehicle Cab does not require tilting for the fitting of the frontal protection device.



Step 2.

Remove 4 bolts and 1 push clip fastening each side bumper end covers, retain bumper end covers and fasteners for refitting.

Retain bumper end cover and fasteners.

Remove 4 bolts and 1 push clip



Step 3.

Remove 6 push clips from the top of the upper grill, pull each side of the grill outward and slide up.
Remove and retain the grill and fasteners for re-fitting.

Upper grill



Step 4.

Remove 6 push clips retaining the lower grill, carefully pull the grill outward to release, retain the grill and fasteners for re-fitting.
Remove and discard fasteners retaining each of the upper steps.
Remove and discard plastic steps.

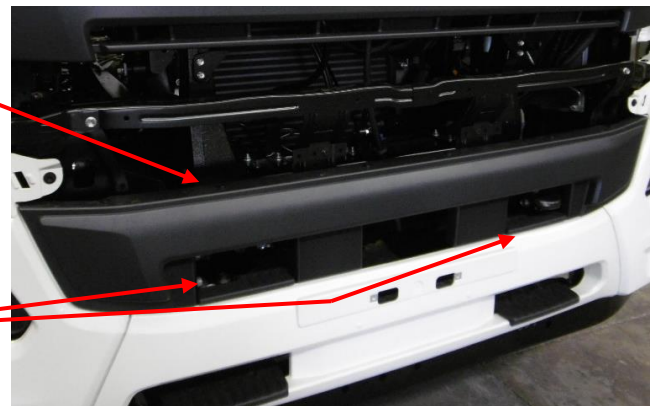

Step 5.

Remove 3 fasteners retaining each of the lower steps.
Remove 2 bolts from the centre of the bumper and Remove 10 bolts from under the lower front edge of the bumper.
Remove the remaining push clips.
To remove the plastic bumper skin lift upwards slightly releasing it from the steel subframe.
Retain the bumper skin and lower steps for re-fitting.

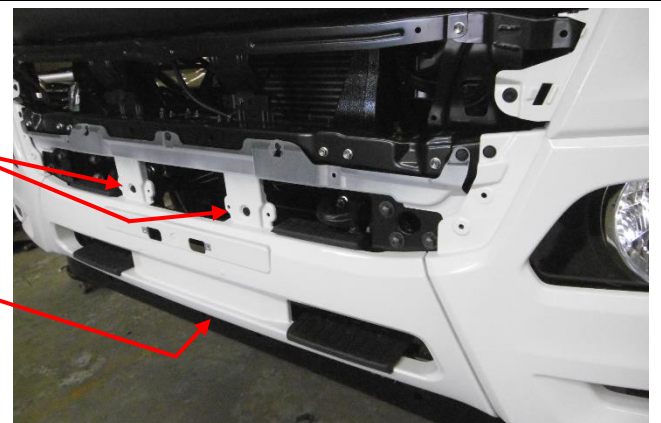

Step 6.

Remove the upper step mounts left behind after bumper skin removal and discard.
Disconnect and remove each of the fog lights from the subframe.
Install harness extension to wiring harness.
If required, remove a wiring loom retainer to allow extra length for the fog light wiring to reach the fog light when mounted in the Bull bar.
Retain the fog light for re-fitting.
Discard the fog light fasteners.



Step 7.

Remove 3 fasteners from each chassis rail.
Retain fasteners for chassis mount fitting.
Note: Image of D/S chassis rail from under the vehicle.

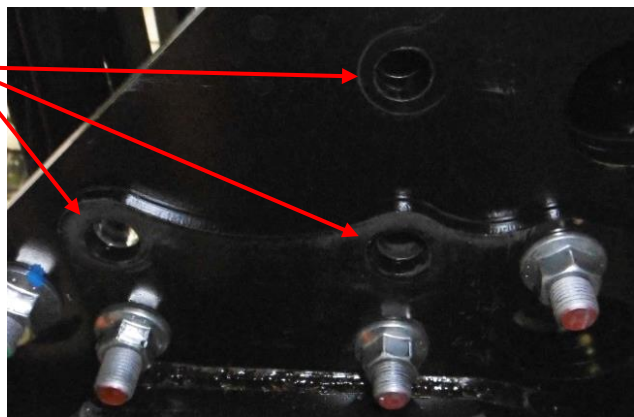

Step 8.

Remove 2 bolts from each side of the subframe and discard.

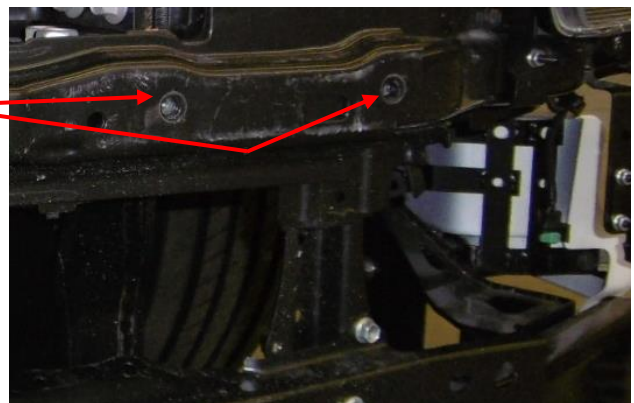

Step 9.

Remove the lower bumper support panels and trim the inner section leaving approximately 280mm to allow the chassis mount to fit up beside it.
Paint any cut edges to prevent corrosion and re-fit using the original fasteners.



Step 10.

Place each side chassis mount under the chassis rail, fit 1 spacer plate between chassis rail face and chassis mount to account for the chassis face height difference, Lightly fasten using the original fasteners through the under side of the chassis, bolts need to be in original orientation eg.nuts under rails.

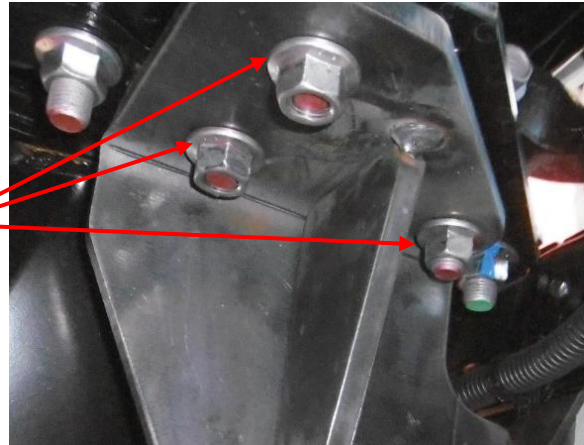

Step 11.

Align the front mount slots centrally and lightly fasten using M8 x 35 x 1.25 bolts, flat and spring washers.

Adjust Chassis mounts to be vertical, parallel to each other measuring 920mm inside to inside.

Tightening sequence is as follows: Under chassis OE bolts working from the front to rear and inside to outside followed by the front M8 chassis mount bolts. Ensure mounts are as far forward as possible

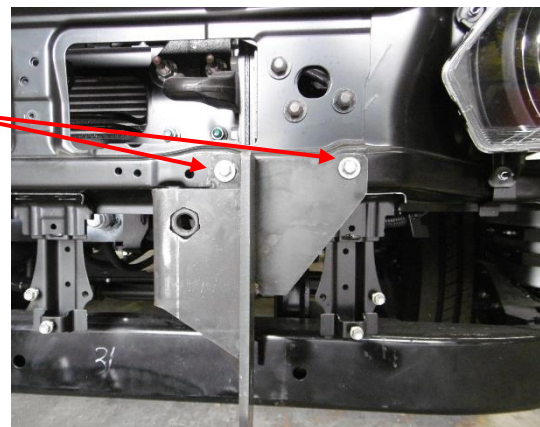

Step 12.

Place the fog lights into the welded fog light mount and fasten using 3 - M6 x 25 x 1.0 bolts, flat washers and wizz nuts each side. No particular tightening sequence.



Step 13.

Mark out the cut line perimeter for the removal of the lower bumper skin centre section of the as follows:-
Align with the bumper upper edge for the top cut line.
Mark a line parallel with the bumper skin join line approximately 45mm towards the centre.
Mark a vertical line 12mm away from the bumper skin fastener hole to complete the lower cut line.

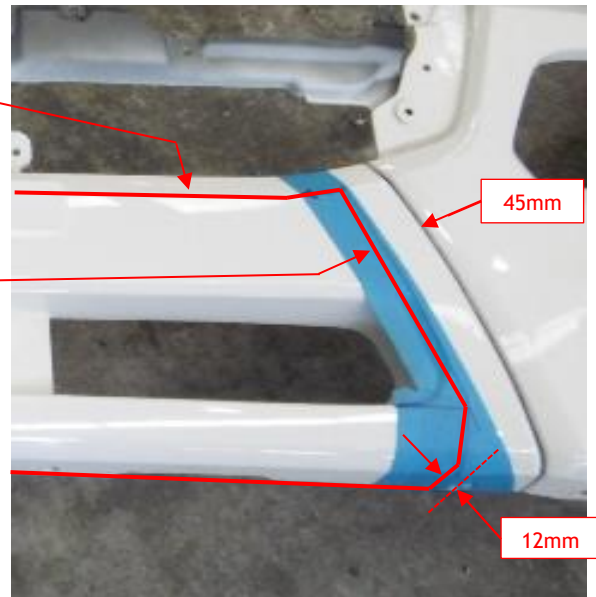

Step 14.

Carefully remove all of the section inside the marked line and discard, refer to image. Smooth cut edges for safety.



Step 15.

Replace the bumper and bumper side covers in the reverse order of removal using the original fasteners.
Re-fit the grill sections using the original fasteners.

Refit 4 bolts and 1 push clip

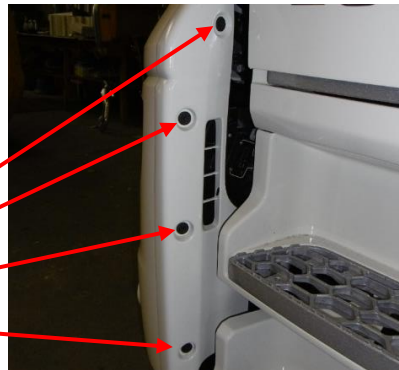

Step 16.

Place the Bull bar onto the chassis mounts and align the 9/16" x 2-1/2" hinge bolts, flat washers and nuts and fasten until light pressure is applied on the alloy mount plates.

Warning Do not over tighten the hinge bolts.



Step 17.
 Connect the fog lights, close the Bull bar and check for clearance between the fog light and the bumper bar front face. Some of the bumper may need to be cut away if the fog light touches.

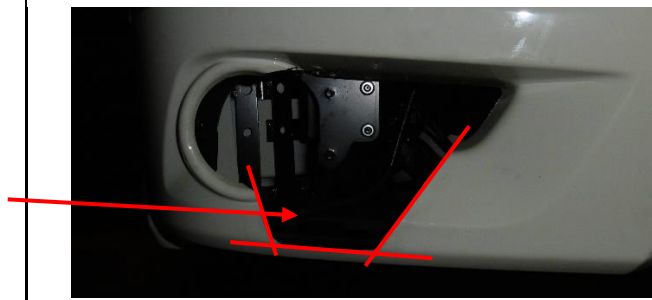

Step 18.
 Align the Bullbar and fasten using 7/8" UNC bolts. The Bull bar channel front face **must** be vertical, it is advisable to use a spirit level to check.

Install Tilt sticker to rear of cabin near latch release handle, and one tilt sticker to prominent position on inside of drivers door.



TORQUE SETTING TABLE TO SUIT ISO METRIC (AS1110.1 / 1110.2 / AS4291.1) & UNC (AS2465 / SAEJ429)

DIAMETER	THREAD PITCH	RECOMMENDED ASSEMBLY TORQUE	
M6	1.0mm	9.1Nm	6.8lbft
M8	1.25mm	22Nm	16.3lbft
M10	1.5mm	44Nm	33lbft
M12	1.75	76Nm	57lbft

DIAMETER	THREAD PITCH	RECOMMENDED ASSEMBLY TORQUE	
1/4"	UNC	14Nm	10lbft
5/16"	UNC	29Nm	21lbft
3/8"	UNC	51Nm	38lbft
1/2"	UNC	125Nm	92lbft
9/16"	UNC	442Nm	326lbft

P2CFHN6510SYF FITTING KIT

- 1 - Pair Chassis mounts (Powder coated black)
- 2 - 6mm Chassis mount Spacers (Powder coated black) (IN BOLT KIT)
- 2 - Tilt stickers (In own bag)
- 1 - extension harness kit (IC17HI500FOGH)
- 2 - 7/8" x 2" UNC Hex Bolts (Fitted to Bar)
- 2 - 7/8" Flat washers (Fitted to Bar)
- 2 - 9/16" x 2-1/2" Hex Bolts (Fitted to Bar)
- 2 - 9/16" UNC Nyloc nuts (Fitted to Bar)
- 4 - 9/16" Flat Washers (Fitted to Bar)
- 4 - M8 x 35 x 1.25 Hex Bolts
- 4 - 5/16" x 1" x 16 Flat Washers
- 4 - M8 Spring washers
- 6 - M6 x 25 x 1.0 hex bolts
- 6 - M6 x 1.0 Wizz Nuts
- 12 - M6 Flat Washers

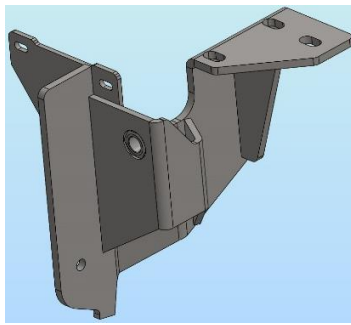

Chassis Mount D/S

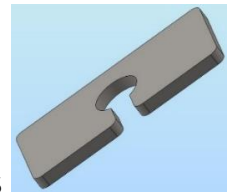

6mm Chassis mount Spacers

P2CFHN6510SYF Bullbar assembly

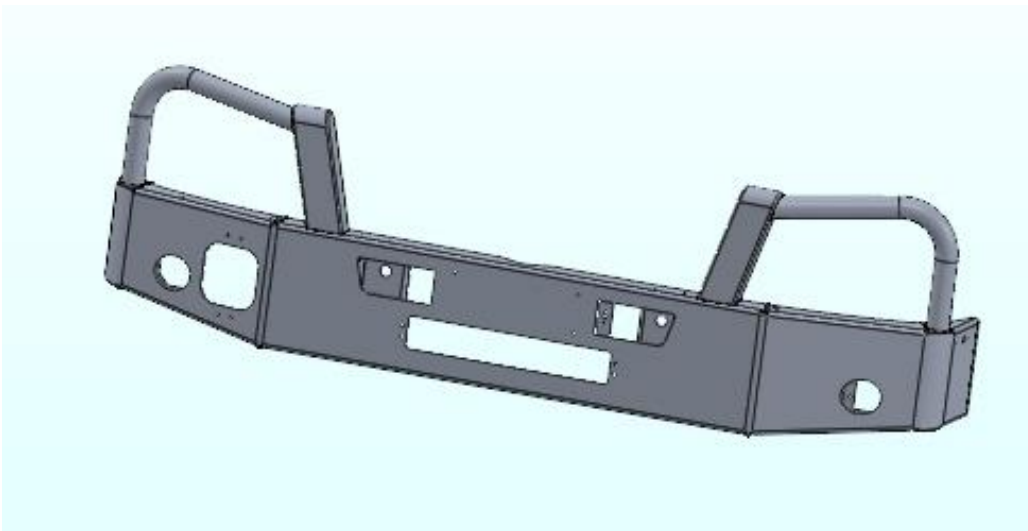



HINO
driven to perfection

Australia

DESPATCH CHECKLIST

REV: A: 07.02.23

P2CFHN6510SYF

HINO 500 SERIES EURO 5 2017+

Work Order #	
Finish:	
Transport:	
Due Date:	

- OC1 - Pair Chassis mounts. (Powder coated black)
- BK2 - 6mm Chassis Mount Spacers. (Powder coated black)
- BK1 - Bolt kit.
- BK..... 1 – extension harness kit (IC17HI500FOGH)
- WR.....2 – 7/8" x 2" UNC Hex Bolts (Fitted to Bar)
- WR.....2 – 7/8" Flat washers (Fitted to Bar)
- WR.....2 – 9/16" x 2-1/2" Hex Bolts (Fitted to Bar)
- WR.....2 – 9/16" UNC Nyloc nuts (Fitted to Bar)
- WR.....4 – 9/16" Flat Washers (Fitted to Bar)

See other side of this page for photos of all mounts



Is this product “the best it can be” Yes

If NO fix before continuing

All parts checked and completed by:

Nut and bolts: _____ Date __/__/__

Order control: _____ Date __/__/__

Final wrap check: _____ Date __/__/__

_____/_____

Wrapper's initials / Checker initials

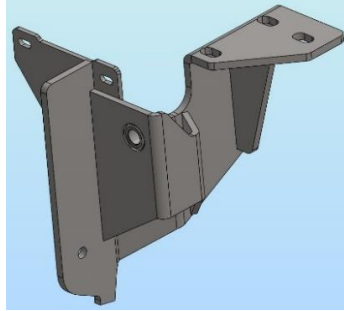

D/S Chassis mount assembly

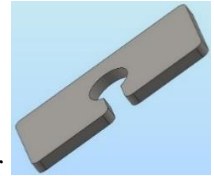

2 – Chassis Mount Spacer

_____/_____

Wrapper's initials / Checker initials

P2HN6510SYF Bullbar assembly

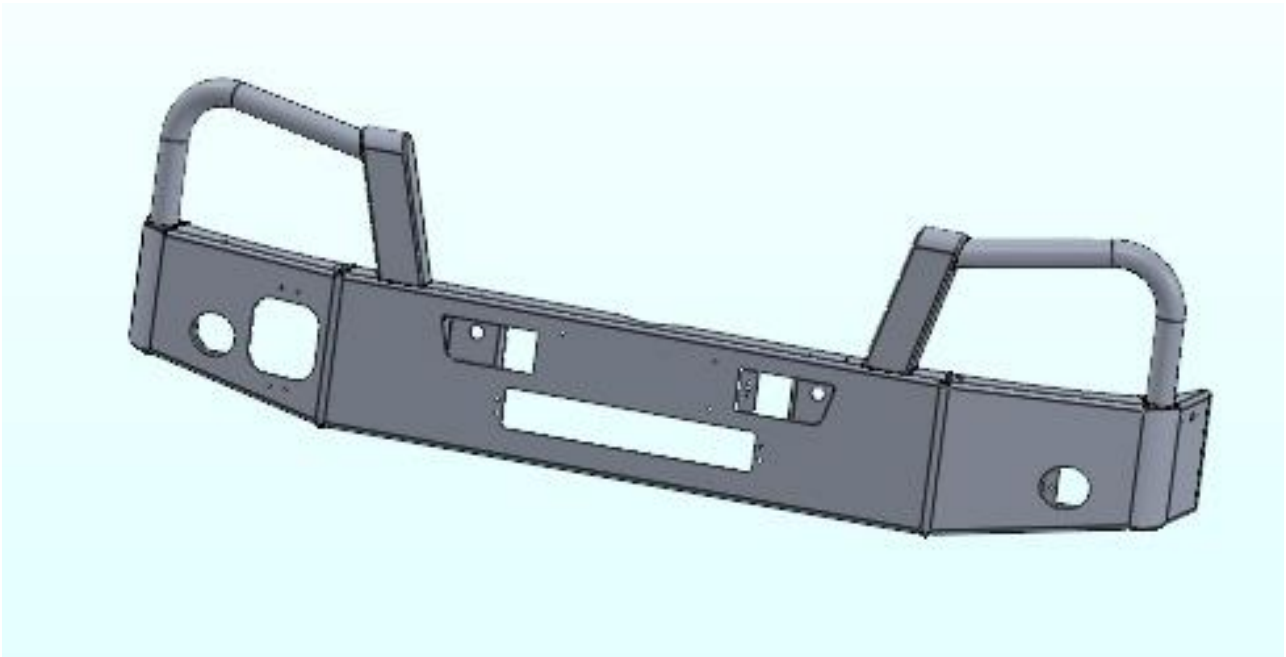

NOTE: Post height is same as side tube height.

